

**FIGURAS DEL EXAMEN
DE
CELULA**



DAGC- LICENCIAS

Por favor no escribir en este manual.

9
23

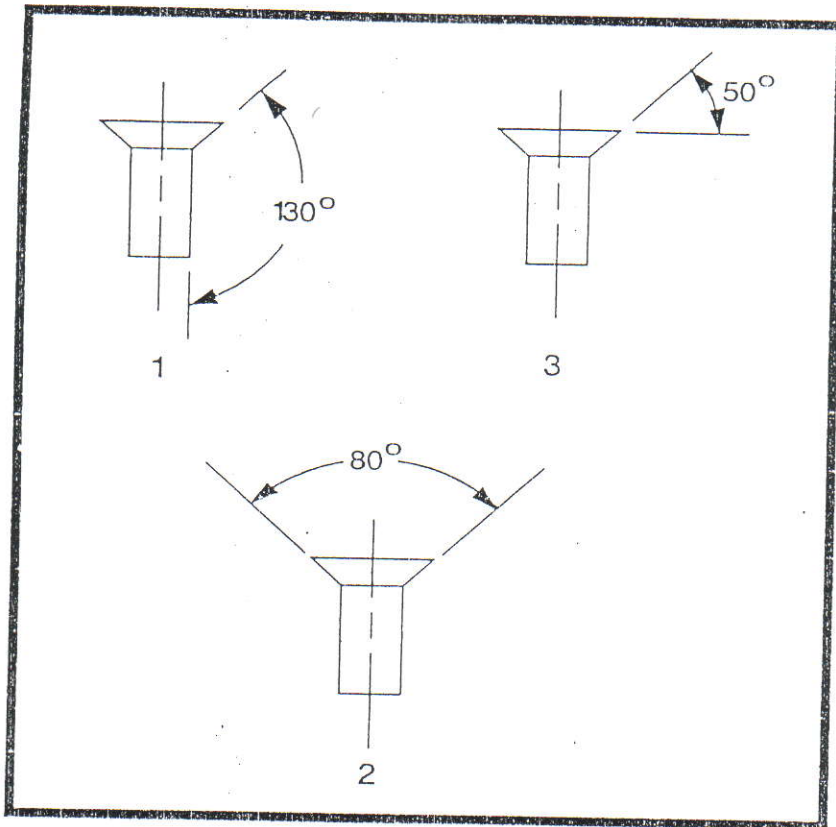

FIGURE 1.—Rivets.

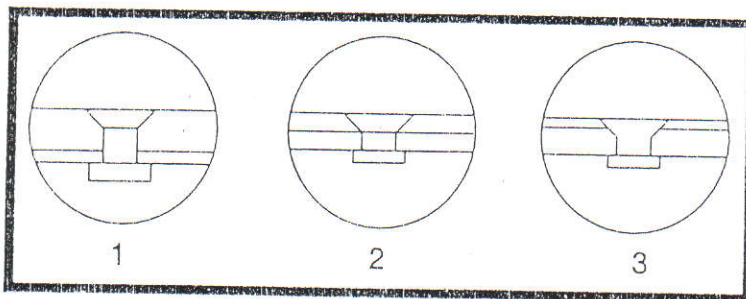

FIGURE 2.—Countersinking.

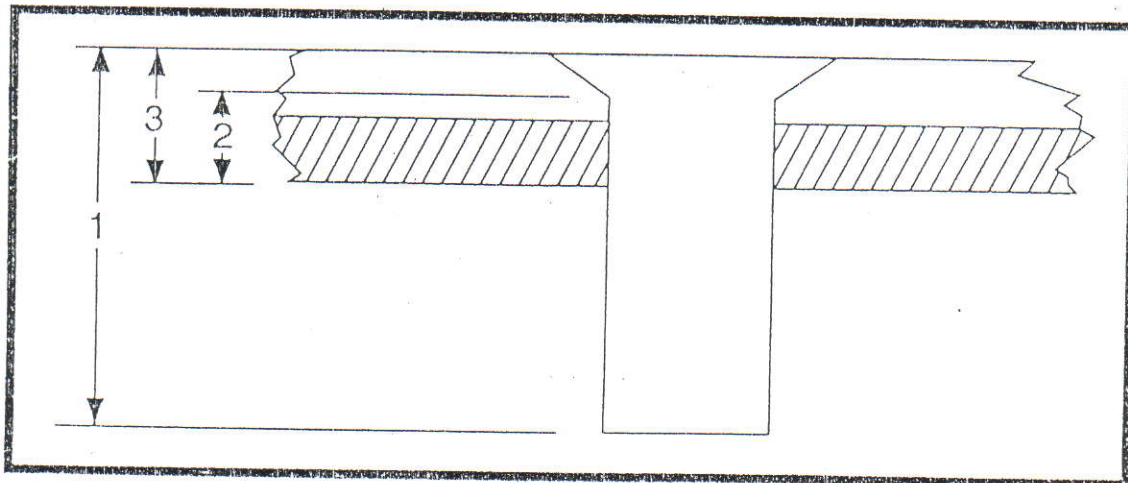

FIGURE 3.—Grip Length.

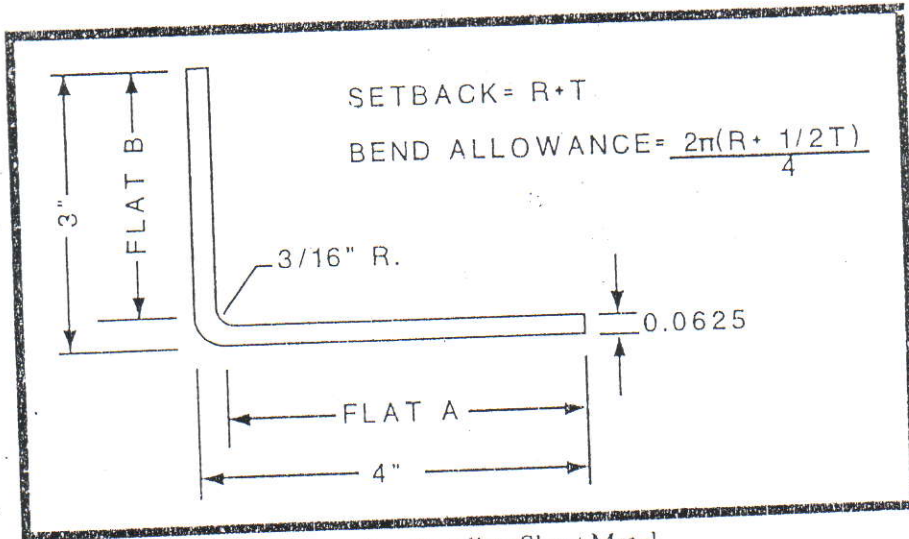

FIGURE 4.—Bending Sheet Metal.

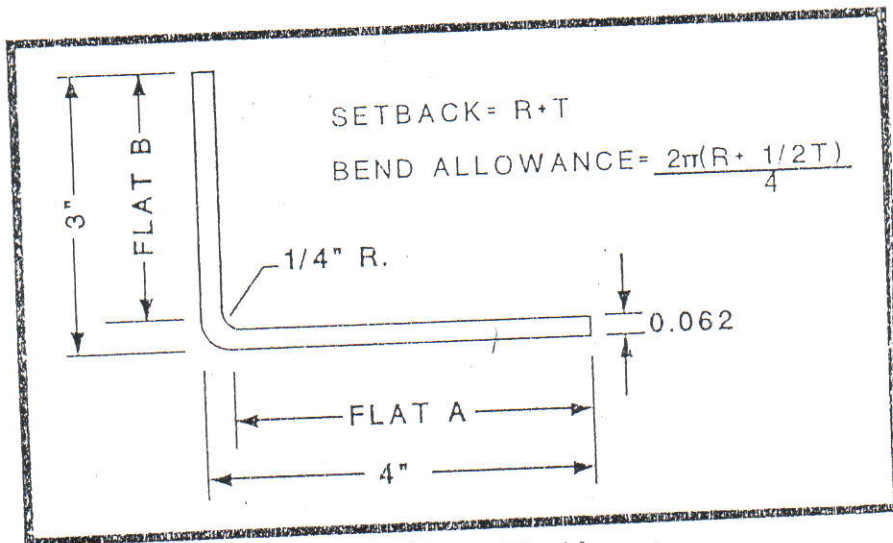

FIGURE 5.—Sheet Metal Layout.

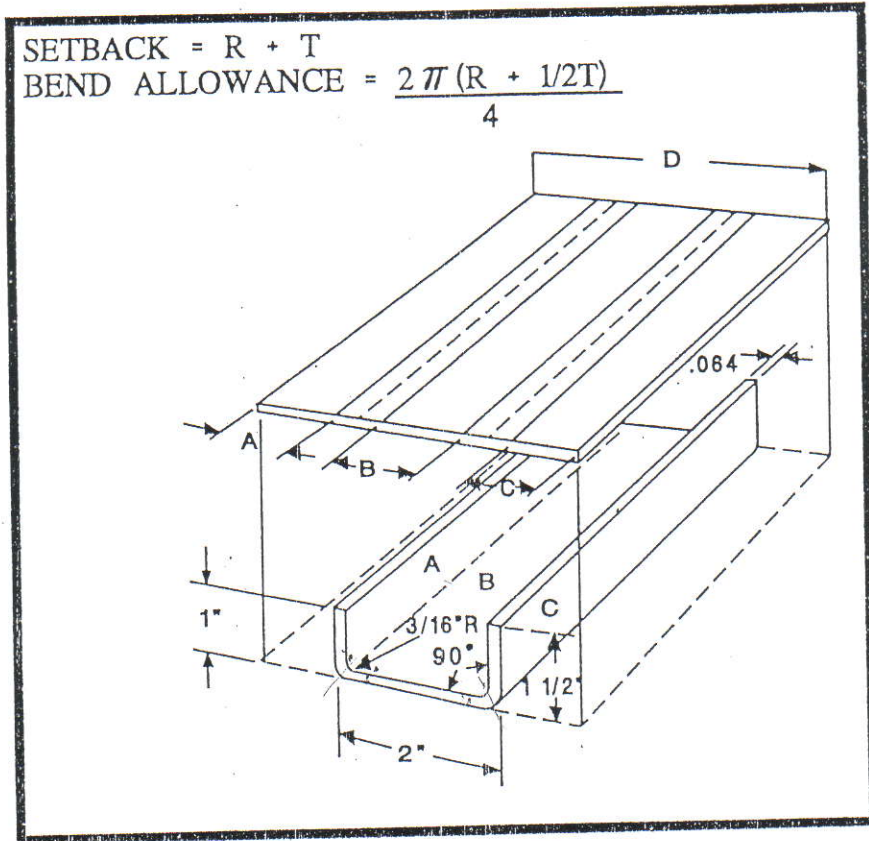

FIGURE 6.—Sheet Metal Layout.

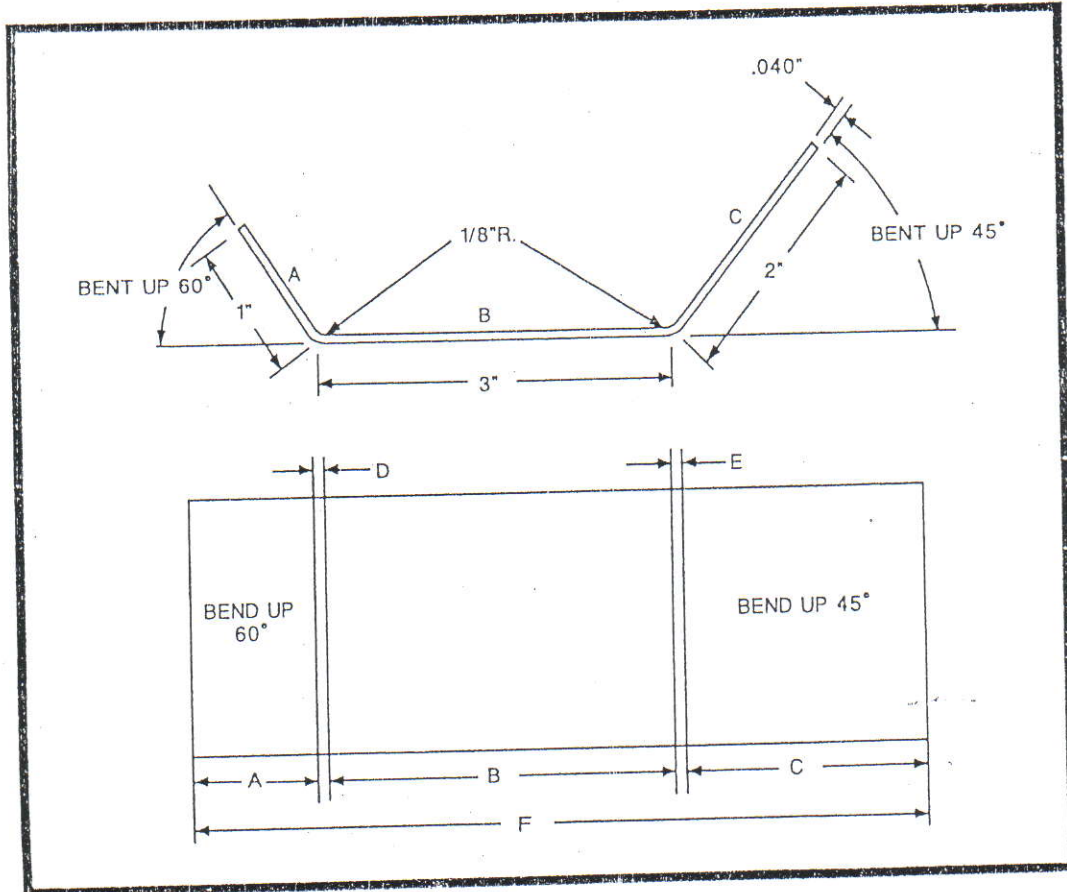

FIGURE 7.—Sheet Metal Layout.

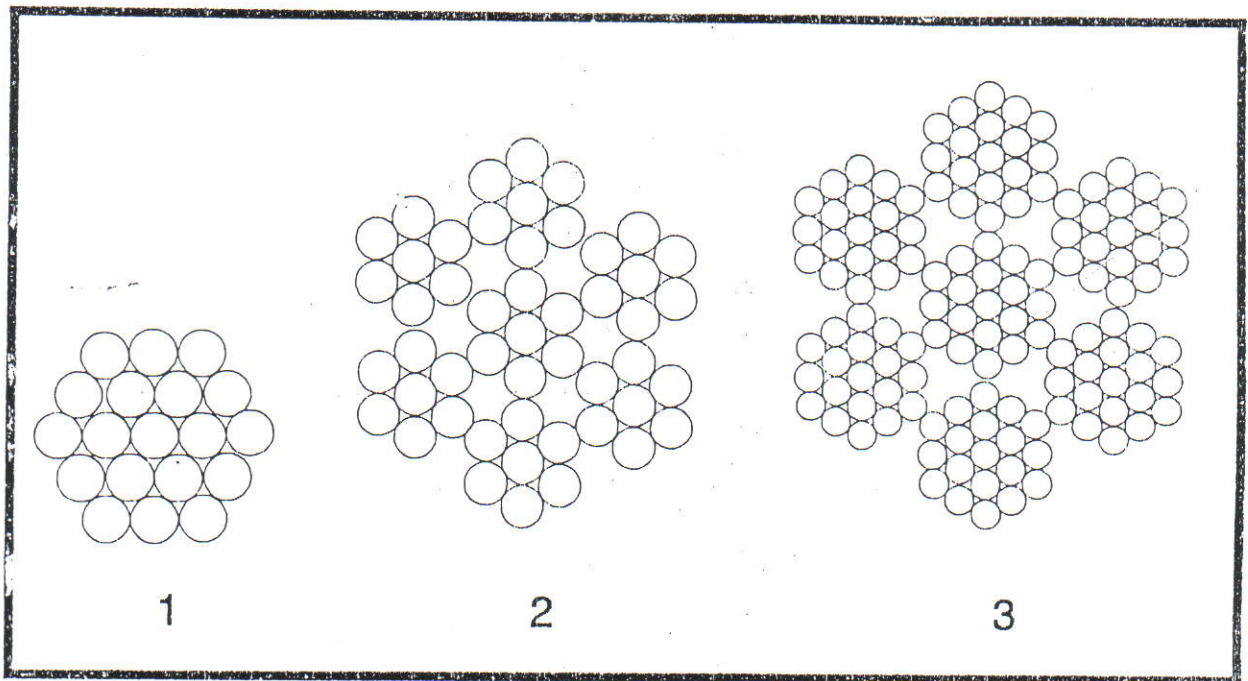

FIGURE 8.—Control Cable.

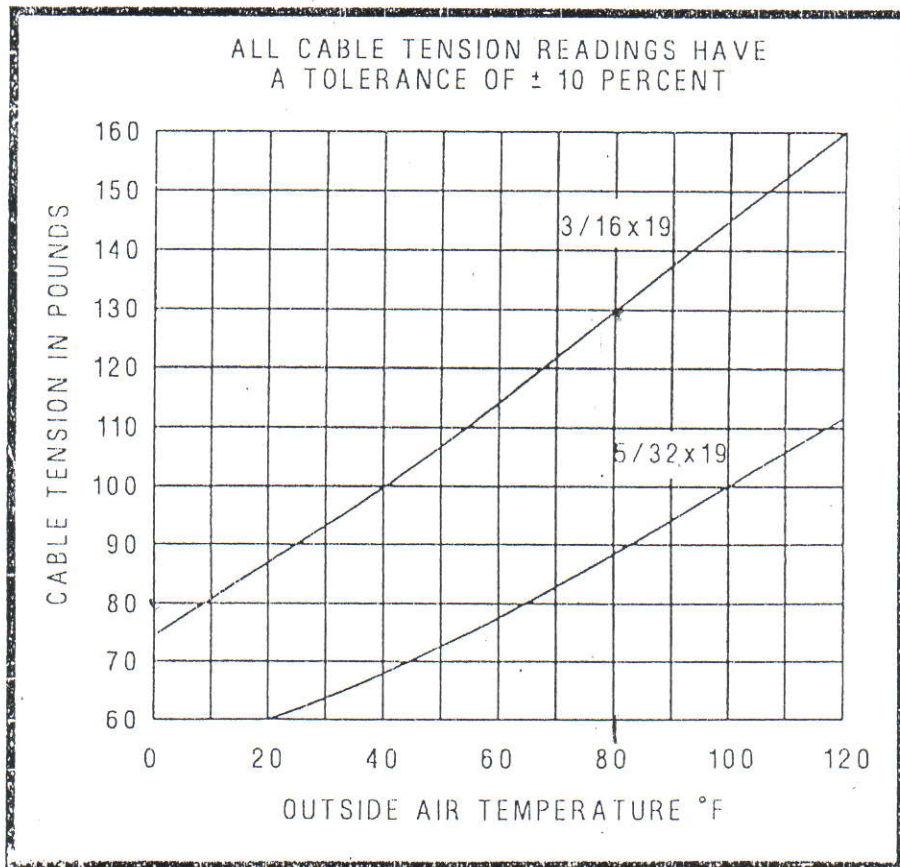

FIGURE 9.—Cable Tension Chart.

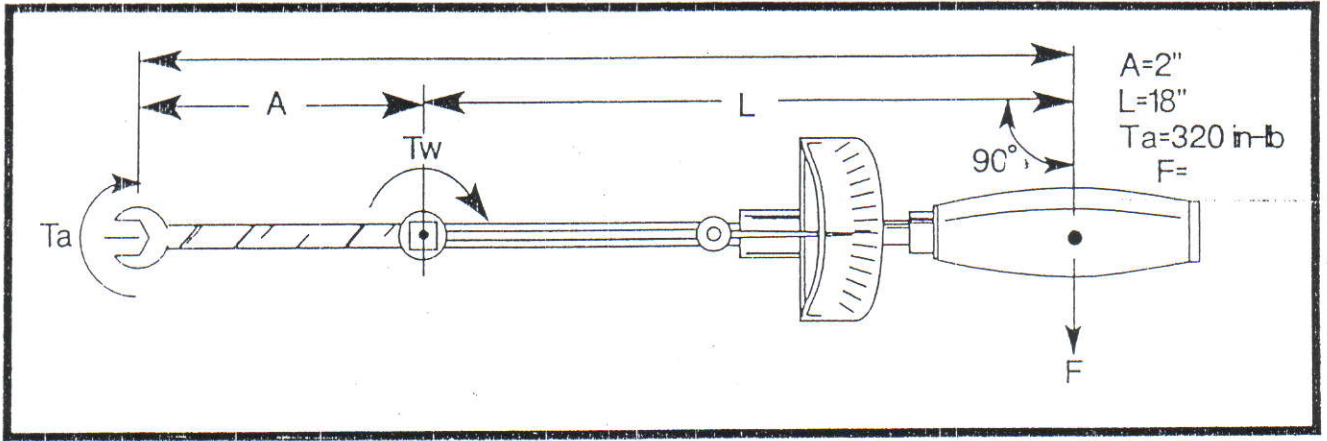

FIGURE 10.—Torque Value.

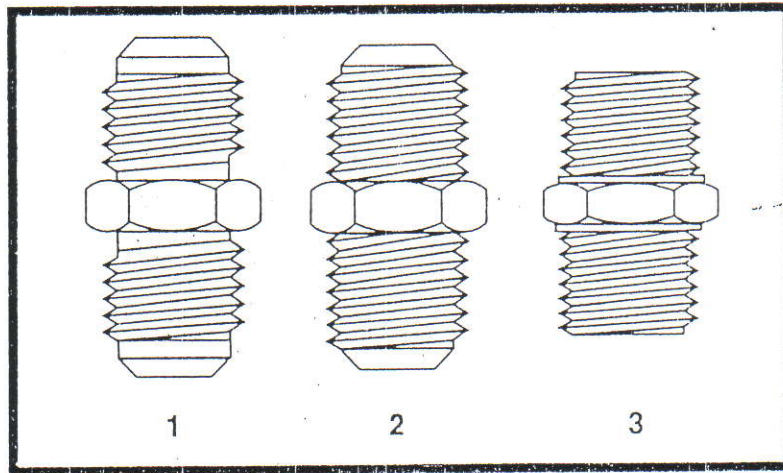

FIGURE 11.—Fittings.

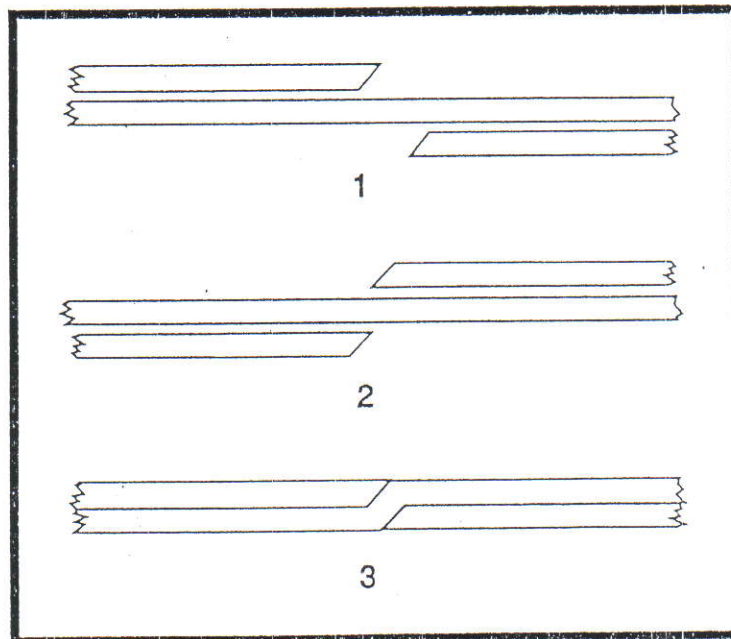

FIGURE 12.—Backup Rings.

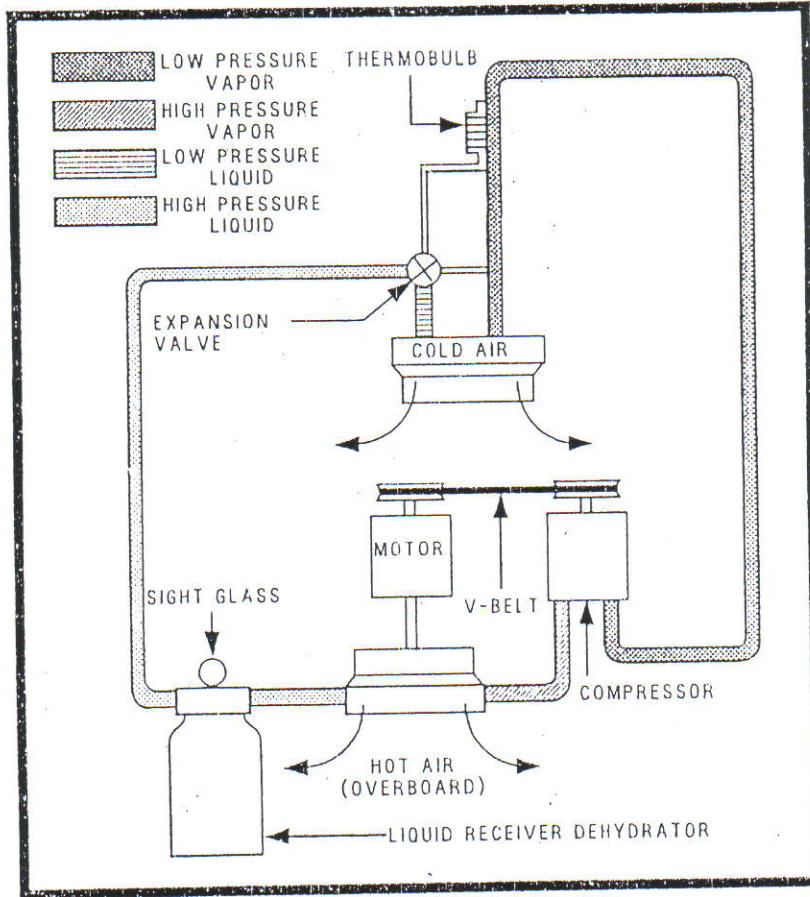

FIGURE 13.—Cooling System.

445 450

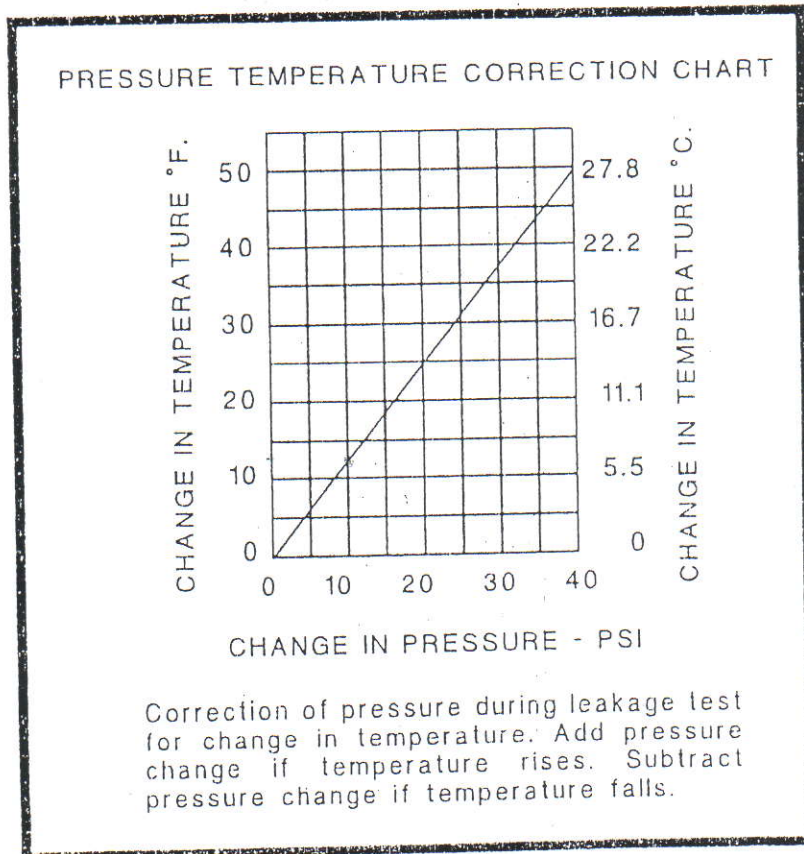

FIGURE 14.—Pressure Temperature Correction Chart.

$$D = .000327AV^2$$

FIGURE 15.—Formula.

G. L. ...

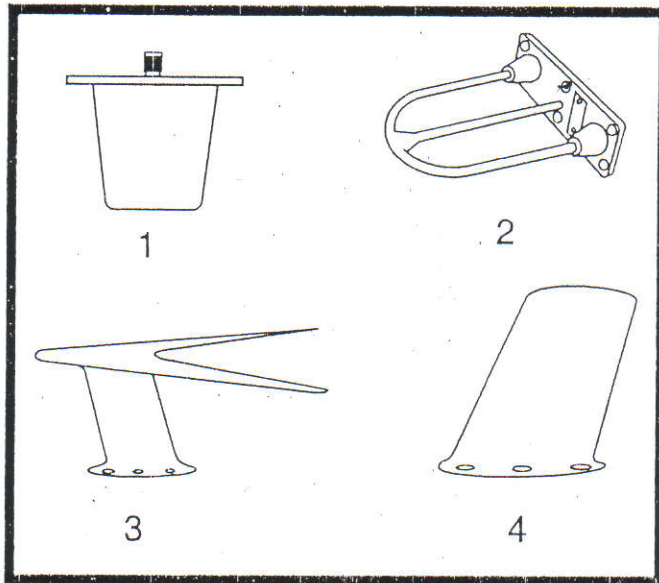

FIGURE 16.—Antennas.

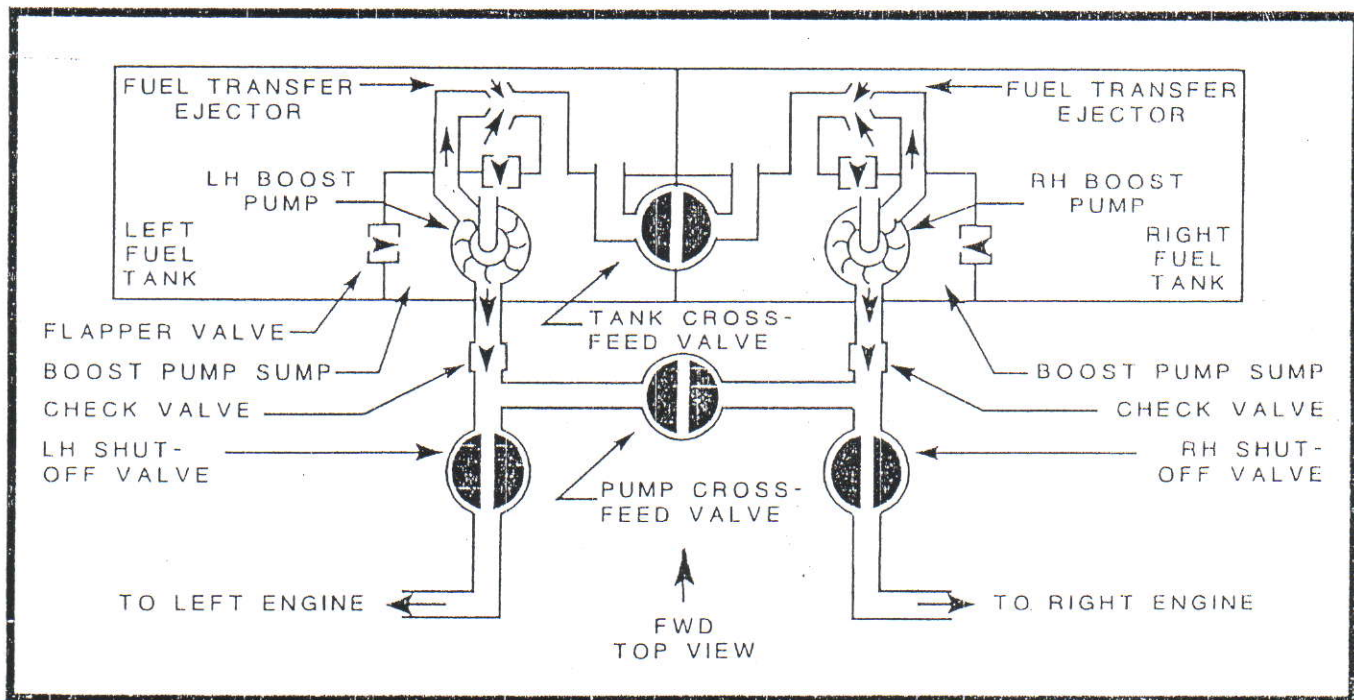

FIGURE 17.—Fuel System.

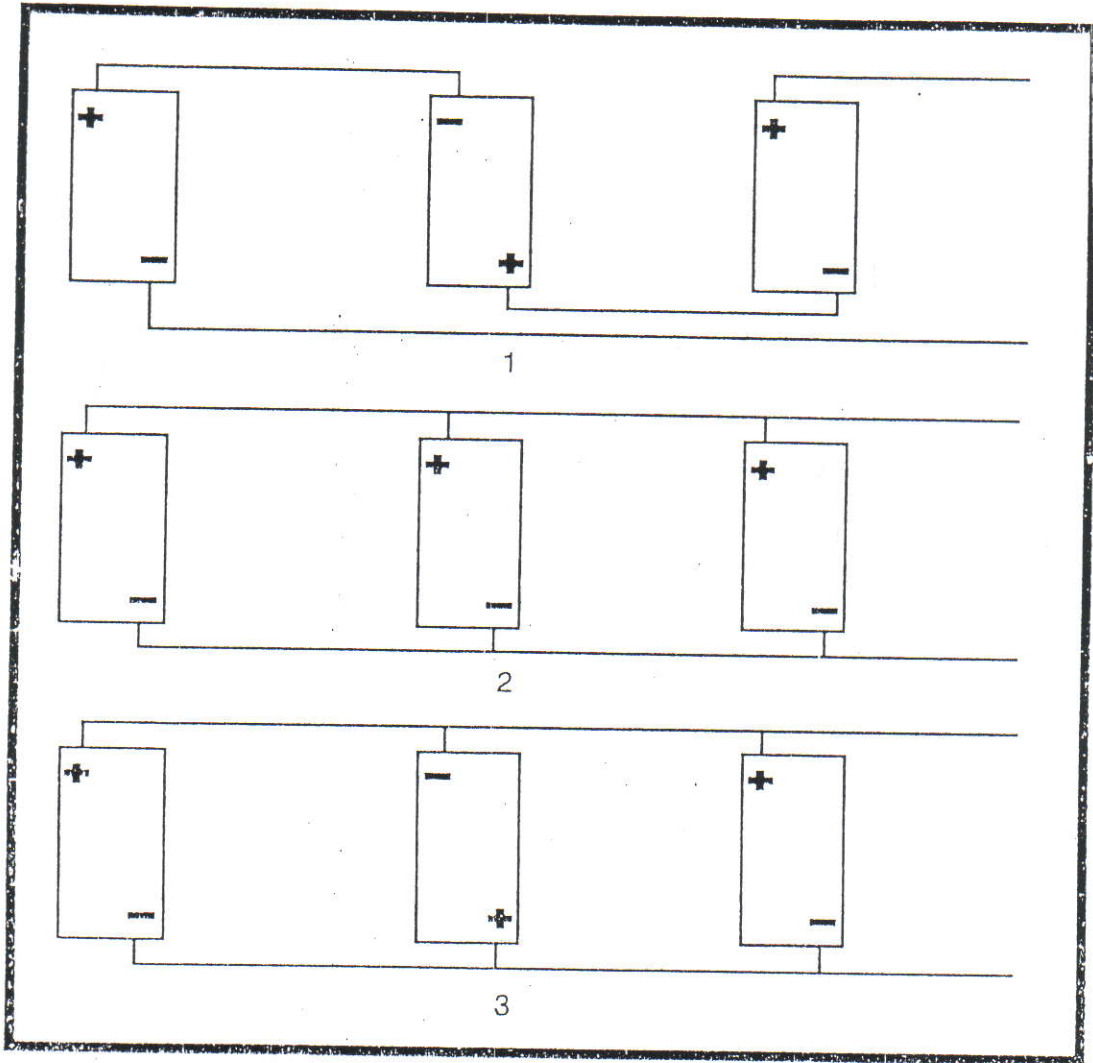

FIGURE 18.—Battery Connections.

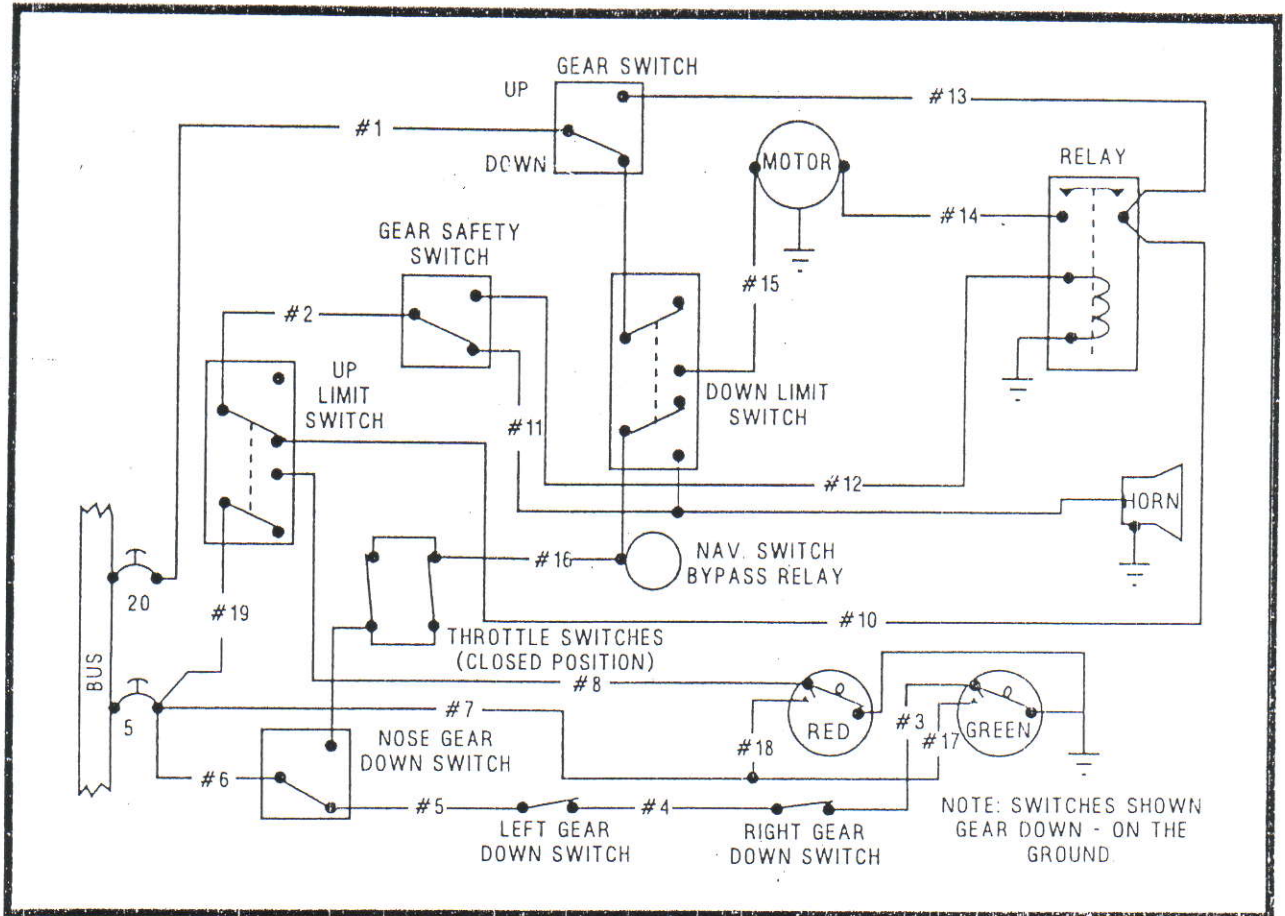

FIGURE 19.—Landing Gear Circuit.

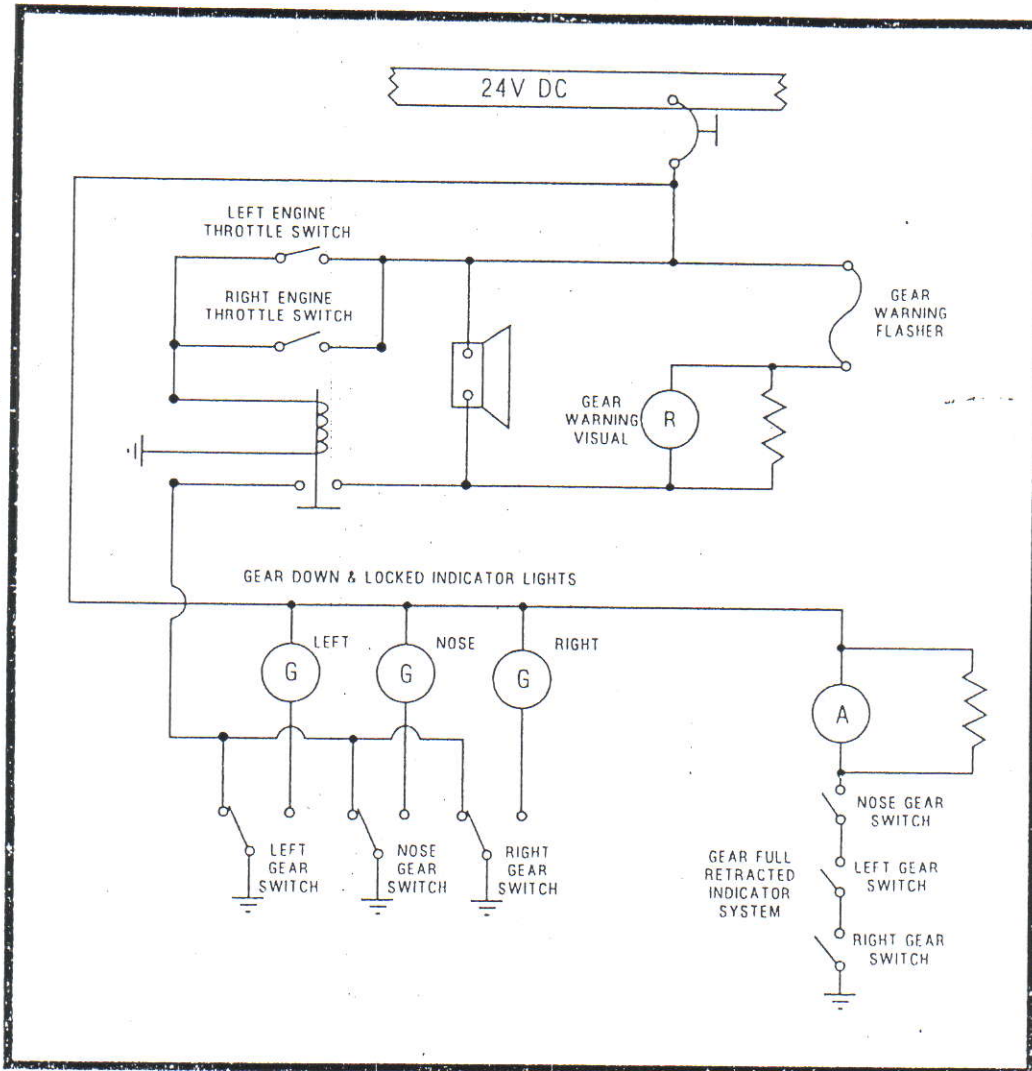

FIGURE 20.—Landing Gear Circuit.

CONTAINER PRESSURE VERSUS TEMPERATURE		
TEMPERATURE °F	CONTAINER PRESSURE (PSIG)	
	MINIMUM	MAXIMUM
-40	60	145
-30	83	165
-20	105	188
-10	125	210
0	145	230
10	167	252
20	188	275
30	209	295
40	230	317
50	255	342
60	284	370
70	319	405
80	356	443
90	395	483
100	438	523

FIGURE 21.—Fire Extinguisher Chart.